

PureLine Brilliant White  
24" Whole Bean Coffee System  
Plumbed

CVA 6805 BRWS



# Whole Bean Coffee System

## CVA 6805 BRWS



### CVA 6805

#### Features:

- M Touch innovative and revolutionary controls are both easy to operate and navigate. An intuitive swipe of the screen will quickly lead you to your desired selection
- OneTouch function prepares two hot beverages in succession when pressing the button twice
- OneTouch for Two operation dispenses two cappuccino or latté macchiato drinks, coffee or espresso simultaneously
- CupSensor recognizes the rim of the cup and alters the spout accordingly
- EasyClick Milk System simply clicks the milk reservoir into and out of place at the front of the machine
- Dishwasher-safe milk flask
- Automatic rinsing and cleaning programs
- Up to 10 user profiles
- The coffee pot function allows up to eight cups of coffee to be brewed at one time
- BrilliantLight
- Timer function
- Ground coffee chute for whole bean bypass
- Removable brew unit for easy cleaning
- Plumbed water connection

### SPECIFICATIONS

#### CVA 6805 BRWS — Item 29680510USA

Overall Unit Width - Excluding Fascia Dimension	21 <sup>7</sup> / <sub>16</sub> " (545 mm)
Overall Unit Height - Excluding Fascia Dimension	17 <sup>1</sup> / <sub>2</sub> " (445 mm)
Overall Unit Depth - Excluding Fascia Dimension	18 <sup>3</sup> / <sub>8</sub> " (460 mm)
Door Depth When Open	23 <sup>7</sup> / <sub>16</sub> " (594 mm)
Overall Fascia Dimensions	23 <sup>7</sup> / <sub>16</sub> " (595 mm) W x 17 <sup>15</sup> / <sub>16</sub> " (455.5 mm) H x 1 <sup>3</sup> / <sub>16</sub> " (22 mm) D

#### Built-In

Minimum Cabinet Width	22 <sup>1</sup> / <sub>16</sub> " (560 mm)
Minimum Cabinet Depth	21 <sup>5</sup> / <sub>8</sub> " (550 mm)
Minimum Cabinet Height	17 <sup>11</sup> / <sub>16</sub> " (450 mm)
Minimum Base Support	62 lbs

Additional Cut-outs Required	Venting: 19 <sup>11</sup> / <sub>16</sub> " (500 mm) x 1 <sup>9</sup> / <sub>16</sub> " (40 mm) or 31" in <sup>2</sup> (200 cm <sup>2</sup> )
------------------------------	-----------------------------------------------------------------------------------------------------------------------------------------------------

#### Plumbing

Do not Connect to Reverse Osmosis (RO) System

Water Supply Requirements	Connect to a cold water supply only. Must be connected to a shut-off valve. The water shut-off valve must be accessible after installation. The water pressure must be between 14.5 psi (1 bar) and may not exceed 145 psi (10 bar). If the pressure is higher than 145 psi (10 bar), a pressure reducing valve must be installed.
---------------------------	------------------------------------------------------------------------------------------------------------------------------------------------------------------------------------------------------------------------------------------------------------------------------------------------------------------------------------

Water Connection Line	<sup>3</sup> / <sub>4</sub> " BSP to <sup>1</sup> / <sub>4</sub> " Compression fitting is supplied. Suitable <sup>1</sup> / <sub>4</sub> " O.D flexible water line or copper piping is not supplied. Maximum water line length 4'11" (1.5 m).
-----------------------	-----------------------------------------------------------------------------------------------------------------------------------------------------------------------------------------------------------------------------------------------

#### Electrical

Electrical Requirements	120V, 60Hz, 15A
Power Cord	Molded NEMA 5-15A plug, 6 ft (1.8 m)

#### Shipping

Shipping Weight	70 lbs
Shipping Dimensions	23 <sup>5</sup> / <sub>8</sub> " W x 22 <sup>1</sup> / <sub>16</sub> " H x 26" L

#### Support

Call Miele	800.843.7231
Miele Website	<a href="http://www.mieleusa.com">www.mieleusa.com</a>
20/20 Link	<a href="http://2020technologies.com">2020technologies.com</a>

# Whole Bean Coffee System CVA 6805 BRWS



## PRODUCT VIEWS

Isometric View

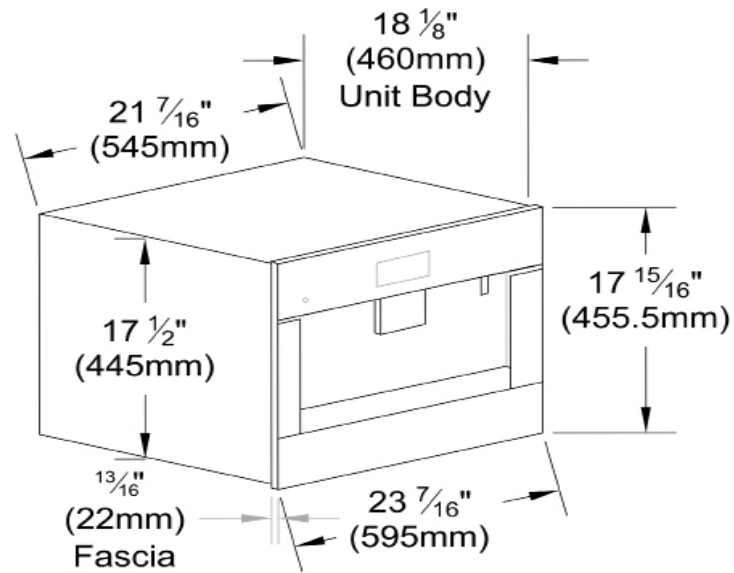

Top View, Door Open

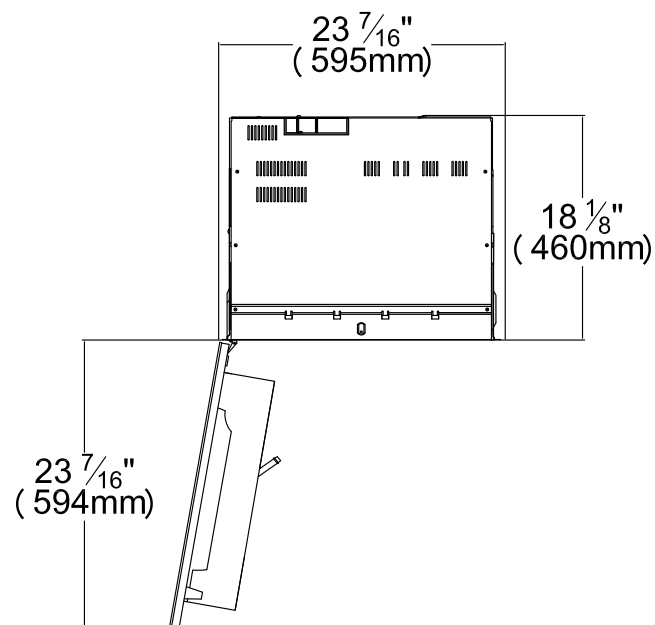

# Whole Bean Coffee System CVA 6805 BRWS



## PRODUCT VIEWS

### Front View

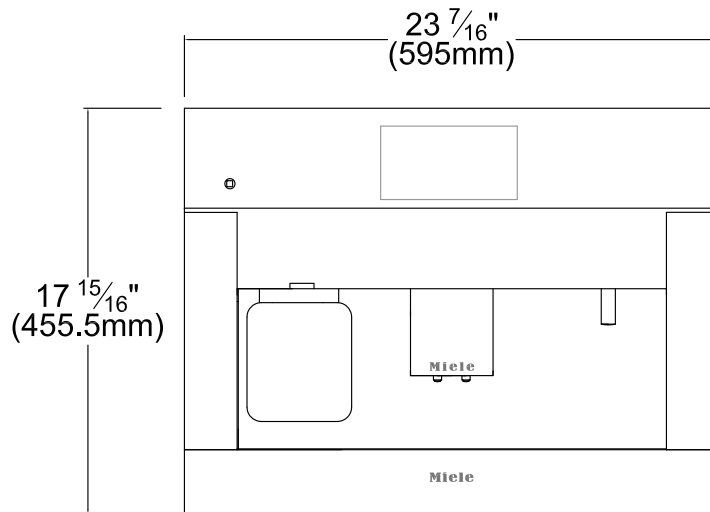

### Side View

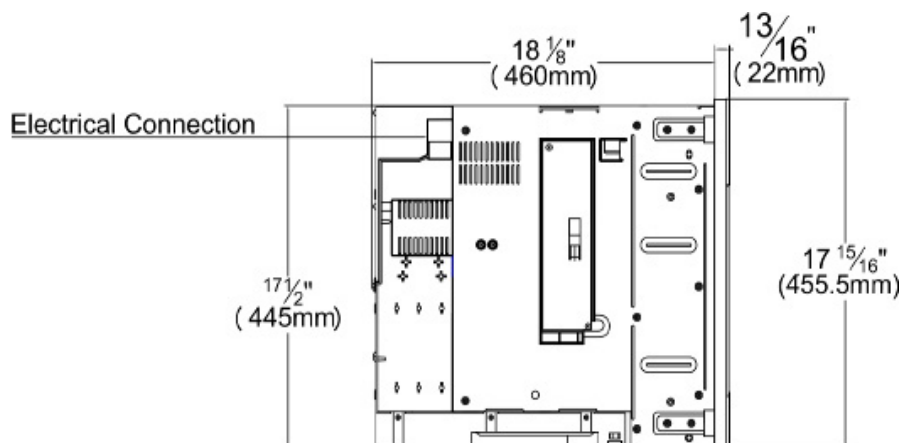

PRODUCT VIEWS

Rear View

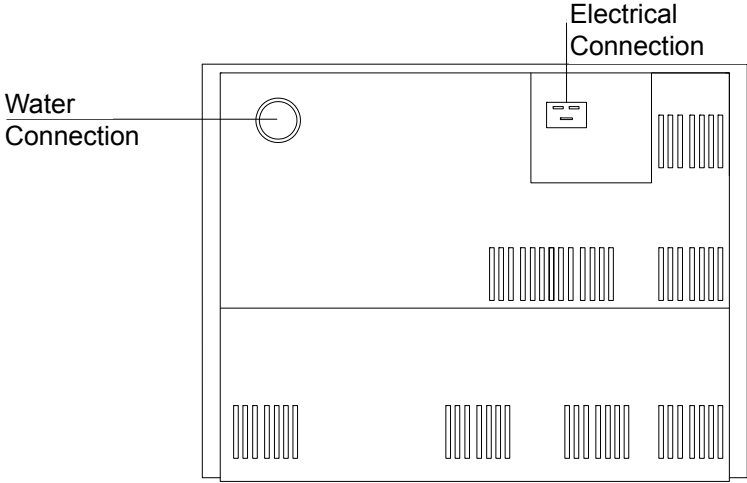

INSTALLATION SPECIFICATIONS  
Cutout Dimensions

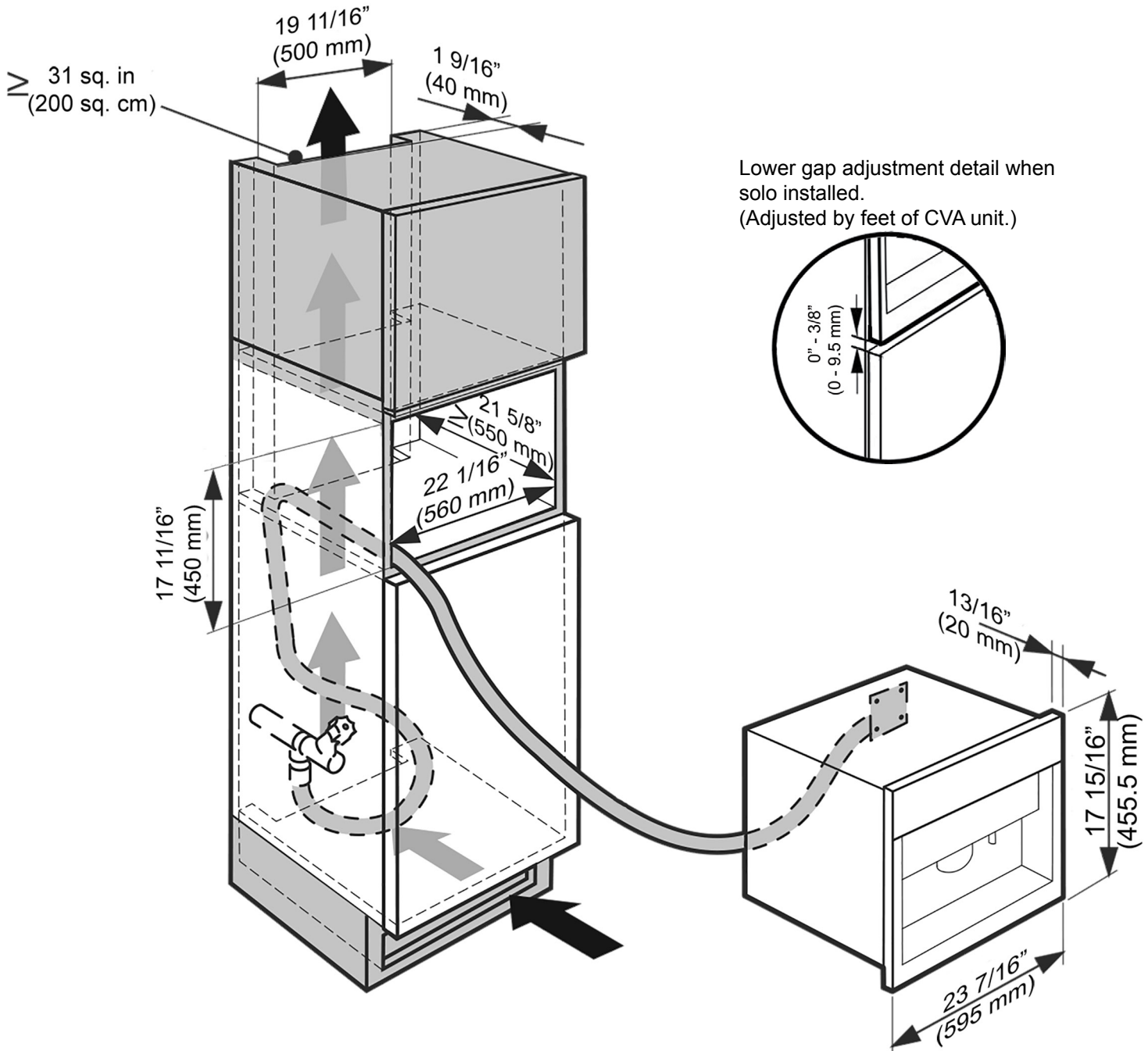

**PLEASE NOTE:** Condensation water can damage the coffee system or surrounding cabinets. The specified ventilation cross-sections absolutely must be observed.



## INSTALLATION SPECIFICATIONS Ventilation Requirements

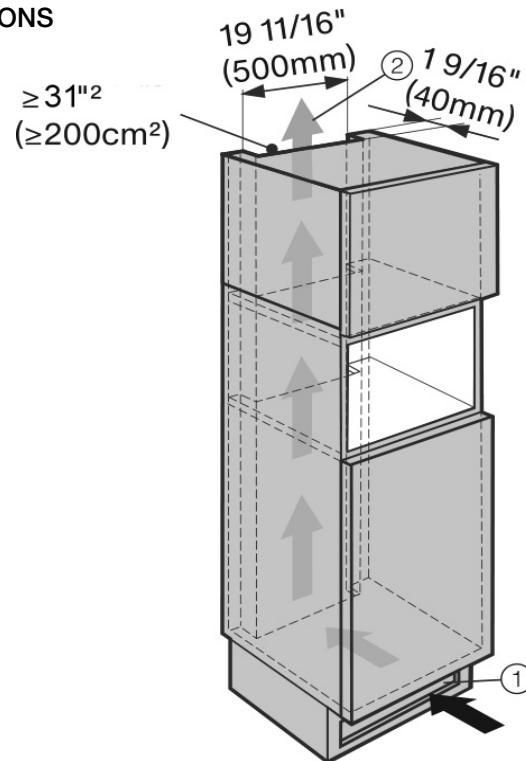

Air intake ① occurs via the plinth at the bottom of the appliance and the air escapes at the top ② at the rear of the surrounding cabinets.

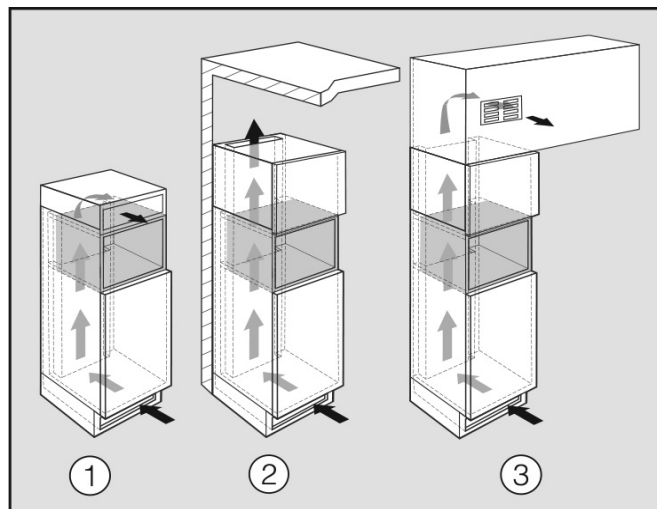

- ① directly above the coffee system with a ventilation grille (free airflow of at least 31 square inches / 200 cm<sup>2</sup>)
- ② between the surrounding cabinets and the ceiling
- ③ through a suspended ceiling

**PLEASE NOTE:** Condensation water can damage the coffee system or surrounding cabinets. The specified ventilation cross-sections absolutely must be observed.

# Whole Bean Coffee System CVA 6805 BRWS



## INSTALLATION SPECIFICATIONS With Warming Drawer

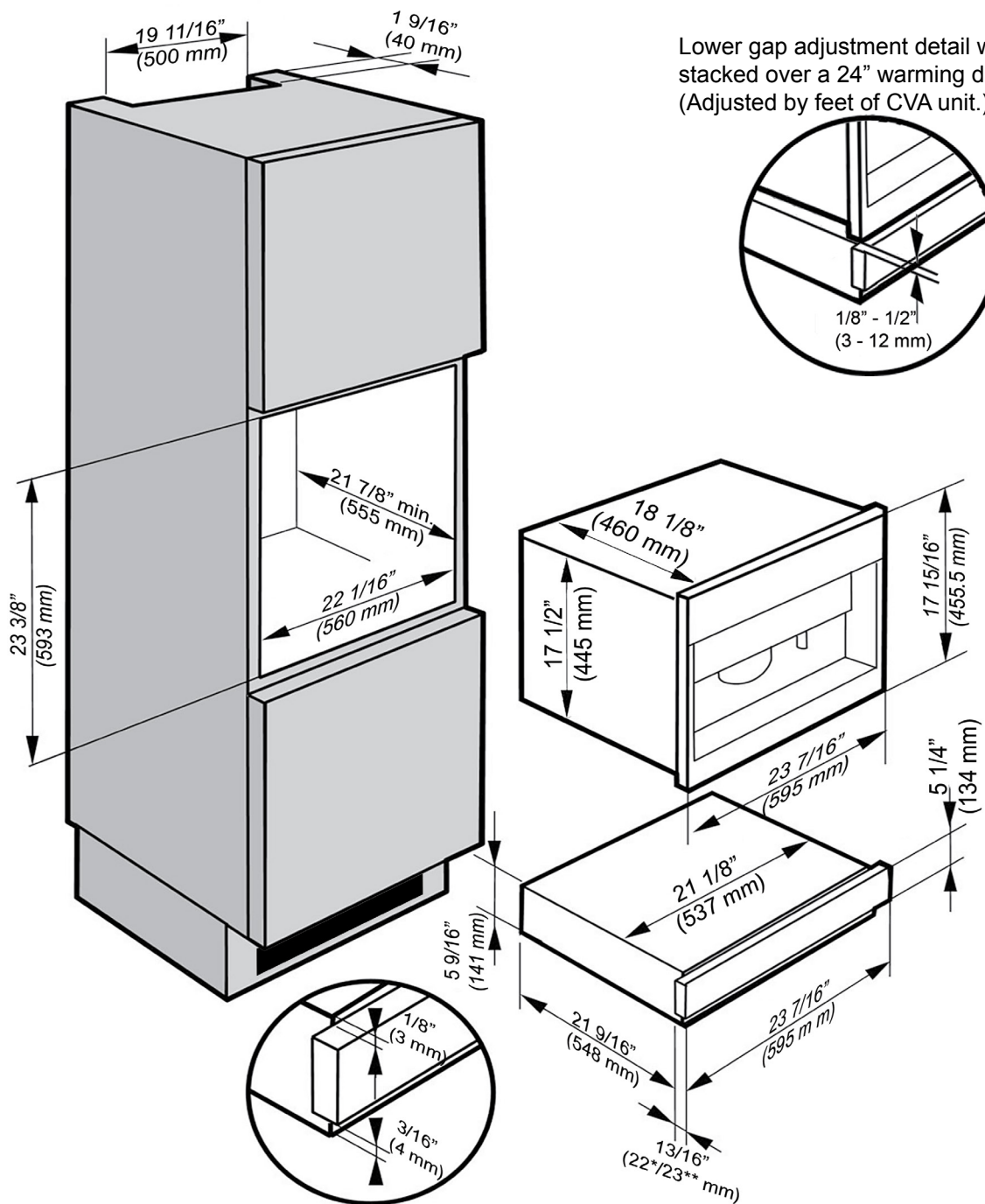

**PLEASE NOTE:** Condensation water can damage the coffee system or surrounding cabinets. The specified ventilation cross-sections absolutely must be observed.